

Flow Standard 1100

Flow Calibrator

The Ecotech Flow Standard 1100 is used to calibrate mass flow controllers (MFC's) used in gas calibrators such as the Ecotech GasCal 1100. The Flow Standard 1100 also features 'Autocal' software automatically checks expected and actual gas flow rates then resets the gas calibrator to the correct level.

Features

- Accurate calibration of MFCs to ensure correct operation.
- 'AutoCal' automatically calculates and resets MFC coefficients.
- Use when multiple gas calibrators need calibration.
- Faster, easier and more accurate than manual methods.
- Available as a rack mounted (19") or bench top versions.

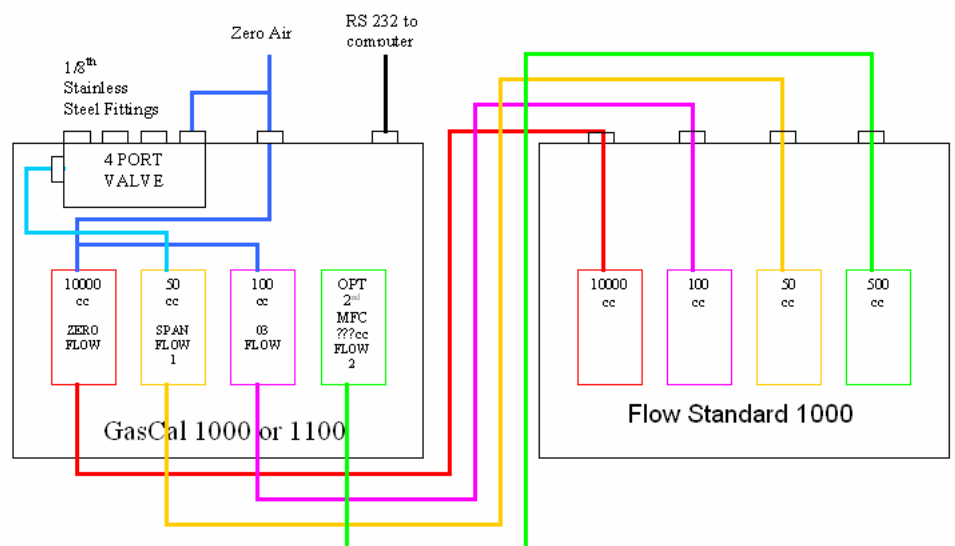

**ECOTECH**WORLD CLASS
environmental
MONITORING

Specifications

Dilution and Span flows:

Flow Accuracy (constant temp):	Within 1% of full scale
Flow Repeatability:	Within 0.15% of full scale
Linearity:	Within 0.15% of full scale
Operating Gas Pressure:	100-200 kPa
Zero Drift:	< 0.58% per year
Response Time:	< 5 seconds

Programming:	Via front panel keypad or computer
Digital inputs:	8 digital input bits can start/stop calibration sequences
Digital Input Types:	Relay contact closures or TTL logic inputs
Digital Outputs:	8 digital output bits send status and alarms
Display:	Four line illuminated display
Memory:	Non volatile protected, automatic startup after power failure

System:

Operating Temperature:	0° – 50°C (20° - 35°C for optimum performance)
Input Voltage:	100-120V or 200-240V AC (switch selectable) 50/60 Hz
Dimensions:	19" Rack mount (135mm H x 450mm W x 440mm D) (Rack mounting drawer optional extra)
Weight:	11kg

Autocal System Requirements:

CPU	Intel PII 233MHz +
RAM	32MB
Display	SVGA - Supporting 800x600.
Hard Disk	5MB + space.
Com Ports	2 x RS-232 ports (GasCal and Flow Standard).
Operating System	Windows 95, Windows 98, Windows ME, Windows 2000, Windows XP or Windows NT 4.0+
Software	Office 97 or Excel 97 or higher



USA contact details

Ph: (401) 247 0100

Fax: (401) 537 9166

Email: info@AmericanEcotech.comWebsite: www.AmericanEcotech.com

2006 Governor of Victoria

Export Awards

Winner

BRO 0045 07-FEB-06